

# 15" Dovetail Jig

Instruction  
Manual  
Part # 3452



## CAUTION:

Please read, understand, and follow all manufacturers instructions, guidelines and owners manuals that come with your power tools. Peachtree Woodworking Inc. and its subsidiaries assume no liability for accidents or injuries caused by improper use of this product.

# Peachtree 15” Dovetail System Instructions

## ***Introduction***

Peachtree 15” dovetail system takes a simple approach to making beautiful thru-dovetail’s, a hallmark of fine craftsmanship. The hardest part about cutting dovetails is marking and cutting the matching angles to one another. That’s what makes this system so easy. We have done the math for you and milled the exact cuts that need to be made in this heavy duty and easy to use jig. The Peachtree dovetail system works with precision bearing guides on the shank of the router instead of using those hard to center brass bushing guides that are available for most routers. Because the bearing is already centered on the bit it makes setting up to cut the joint fast and easy. We have milled the template to match the bearing size so that the bit is perfectly centered and there is no slop, no wear and no waste. Unlike other templates you have seen, our jig will work with two different thickness stock as well as two different widths. This means the type of projects you can create are endless. Lets get started making some joints.

**But first - let’s talk about safety.**

## **Read and follow all safety instructions**

### **Caution:**

Please read, understand and follow all manufacturers instructions, guidelines and owners manuals that come with your power tools. Peachtree Woodworking Supply Inc. and its subsidiaries assume no liability for accidents or injuries caused by improper use of this product.

## **Safety Tips**

Creating dovetails that look like they have been hand cut will add curb appeal or distinction to any of your projects. To get the best performance and results out of your dovetail jig, we recommend the following tips:

1. Always wear safety glasses, hearing protection and dress properly. No loose clothing, hair, draw strings or jewelry that might get caught in moving parts.
2. Keep work area clean. Messy work areas invite injuries.
3. Make deeper or larger cuts in multiple passes and NEVER use dull cutters. Forcing a deep cut in one pass or using a dull cutter can result in injury. Inspect cutters for damage or chips in carbide.
4. Make sure router bit is properly installed in router and do not exceed the recommended rpm
5. Keep all safety guards in place.
6. Always unplug your tools before changing cutters
7. Secure you work. Always use at least two clamps to hold your stock to the jig. Make sure the clamps do not interfere with the cutters on the under side of the jig.
8. Make sure the jig is clean with no build up or debris for smooth operation.
9. Make sure the bearing on the cutter is spinning freely. If not spinning freely it may damage the jig. Keep bearing clean and well lubed with bearing lubrication.
10. Follow all manufacturer safety guidelines provided with you router.

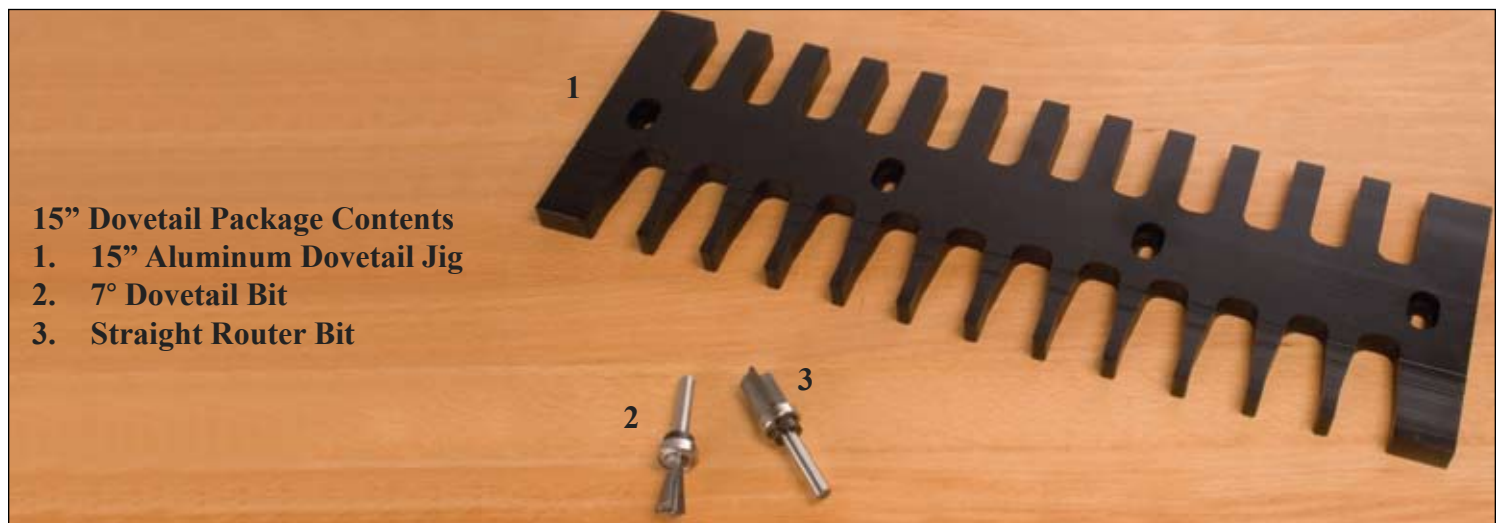

# Mounting The Dovetail Jig

## Prepare the mounting block *(Not Included)*:

The 15" Dovetail Jig is mounted to a piece of stock (mounting block) that acts as a clamping surface for the work-piece. This will also prevent tear-out on the back side of your stock when you cut your joints. It is essential that the mounting block is accurately machined so it is 90° to the dovetail jig. It can be made from a solid block or laminated. The block needs to be 2-1/4" thick x 3-1/2" high x 18" long for use with standard router bits. For different size dovetails we recommend you change your mounting block to provide solid, continuous support when your bit passes through the back of your stock.

## Mount the Jig to Mounting Block:

The first thing you need to do to start using your Peachtree Dovetail jig is mount the jig to the mounting block. The 15" Dovetail Jig has four elongated holes to attach the jig to the mounting block. There are two scribed lines that run across the underside and the top side of the dovetail jig on the pin side of the jig itself (**Fig. 1**). The inside line (toward the center of jig) is used to line up the mounting block when using the standard router bit set for cutting dovetails in 1/2" to 3/4" stock. The outside line is used to line up a wider mounting block or spacer block when using the smaller router bit set for cutting dovetails in 1/8" to 3/8" stock. Match this line to the top edge of the mounting block, it is important that the scribed line on the template jig and the stock are parallel. Drill through the four holes and insert the screws into the middle of the elongated holes. Tighten securely. The 15" Dovetail Jig can be used either in an upright position locked in a vise or inverted onto a router table when working with shorter stock.

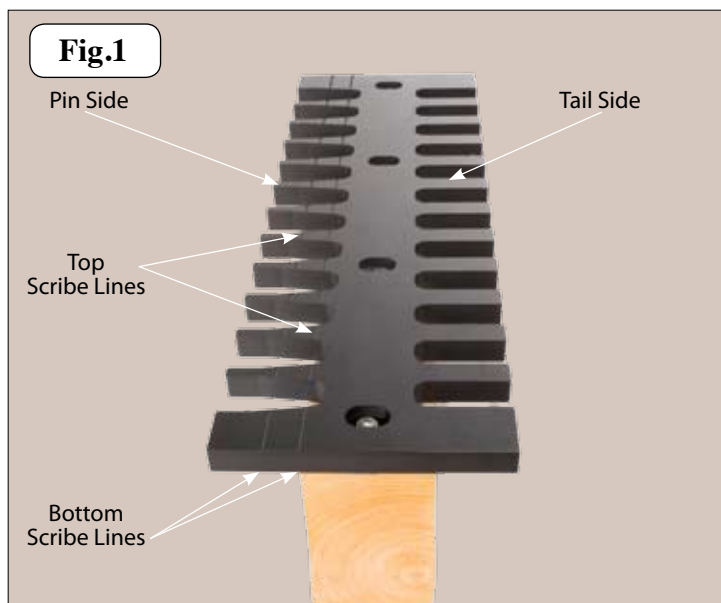

# Cut a Sample Joint

Before making a "live" cut on your project you will need to make a sample cut to test the accuracy of the fit. Follow instructions in the next section on how to make the tail cut and pin cut for your sample joint. When cutting a sample joint, it is important that the stock thickness is the same thickness as your project stock. The standard bit set that came with your jig is capable of cutting 1/2" to 3/4" stock. There are two other bit sets available for your dovetail jig. One bit set will do 1/4" to 1/2" stock and the other set will do 1/8" to 3/8".

# Cutting The Tails

## Making the Tail Cut:

Always start your projects by cutting the tail side first. The reason for this is, the tail cut side of the joint is not able to be adjusted. This makes the joint very accurate because we are working off of the angles of the dovetail router bit. It is the pin side of the joint that can be adjusted to fit the tail cut of the joint.

### 1. Secure stock to Jig

- Prepare the stock to be dovetailed by joining all four edges followed by cutting the ends square. With the Peachtree Dovetail Jig you can use one thickness stock for the tail cut and a different thickness stock for you pin cut.
- Clamp your stock to be dovetailed vertically into you workbench vise. **Fig 2**

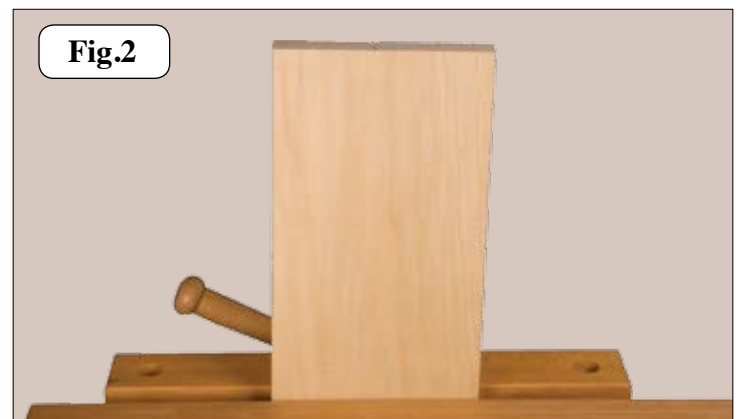

C. Place the mounted dovetail jig (tail side) on the end of stock. Position the jig, so that there are equal distances on either side of the jig. Make sure dovetail jig rest's flat on the tail stock and secure in place with F-clamps or C-clamps. To achieve an exact centered joint, mark the center of your stock, See **Fig. 3**, then measure  $5/16''$  to one side of the center mark and scribe a second line with a pencil. Position the inside edge of one of the tail side openings exactly with the second scribed line See **Fig. 4**. Secure in place with F-clamps or C-clamps. This method will give equal spacing of your tails on either side of your stock.

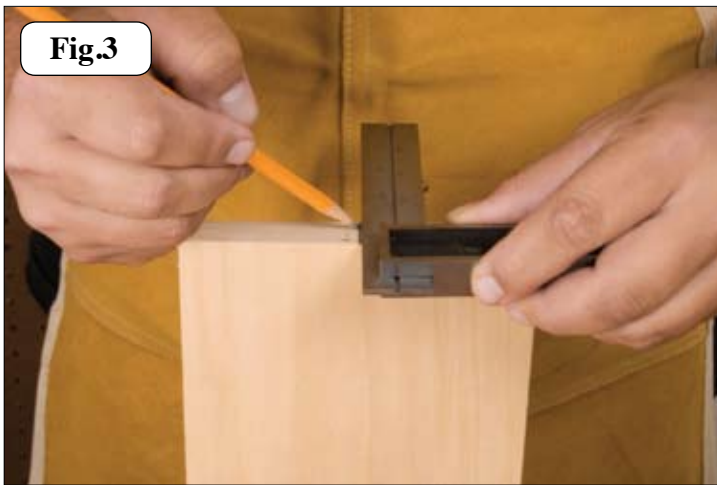

**Fig.3**

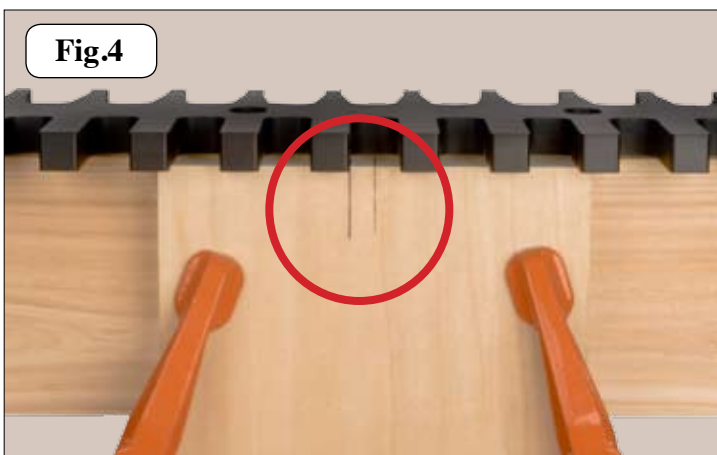
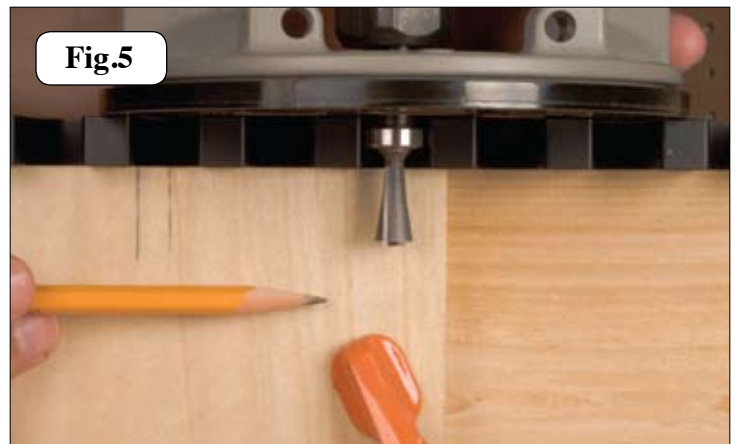

**Fig.4**

**Caution:**

Make sure when clamping your stock to the jig your clamp heads are not in the path of the router bit.

See **Fig.5**



**Fig.5**

E. Place the dovetail router bit with bearing guide into your router and secure router bit collet tightly. Adjust the base of your router for depth of cut by adding the thickness of the pin stock piece plus  $1/2''$  for the thickness of the dovetail jig. If desired, add an additional  $1/32''$  or more for sanding the edge perfectly flush after assembly of joint. Another way of setting your bit height is to place your pin side stock on top of the jig. Place the router with bit on top of stock, with bit hanging over edge between the fingers of the jig. Now lower the router bit until it touches the top of the tail stock and then secure router bit in place.

See **Fig. 6**

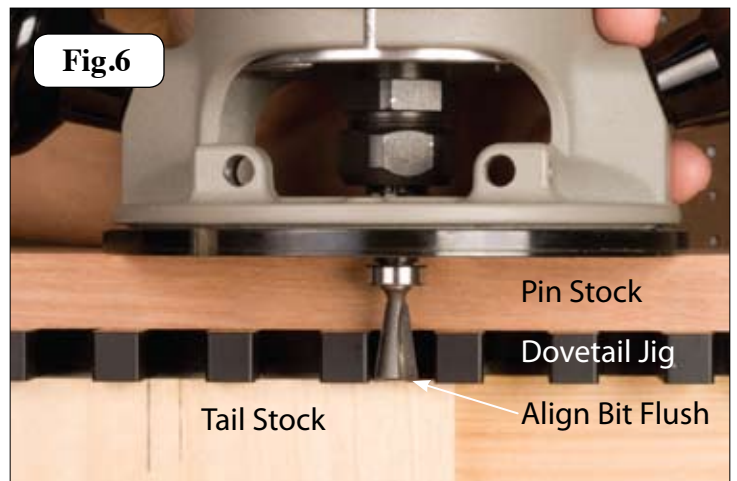

**Fig.6**

**Caution:**

Make sure bearing contacts dovetail jig by at least  $1/8''$  or more before starting cut. If bearing does not contact jig properly it may result in injury or damaging the dovetail jig. See **Fig.7**. In order cut dovetails into thinner stock, you must use optional router bits which are sold separately.



**Caution:**

*To prevent damaging your dovetail jig while router is turned on - Do not tip the router, always keep the router flat on jig. Do not lift the router up between the fingers while router is on. When routing of joint is complete, turn router off and wait for bit to come to a complete stop before removing router off of the dovetail jig. Do not force the router bit, or cut to fast, as this may result in tear-out, splintering of the stock or even loss of control. Moving the router to slow could result in burning of your stock. Feed the router bit into the stock smooth and controllable rate.*

F. (Always wear eye protection) Cut your stock standing behind mounting block. See **Fig. 8**. This will allow you to pull the router towards you while making the cut, giving you a smoother, more controllable cut. This also will keep the wood chips directed away from you. Place your router flat on top of the dovetail jig surface with the bit in between one of the openings. Be sure the cutter is not contacting the wood surface before turning your router on. Holding the router firmly, turn it on, and guide the bearing and router bit through each of the tail side openings, pulling the router all the way back to each of the tail slots, See **Fig. 8**.

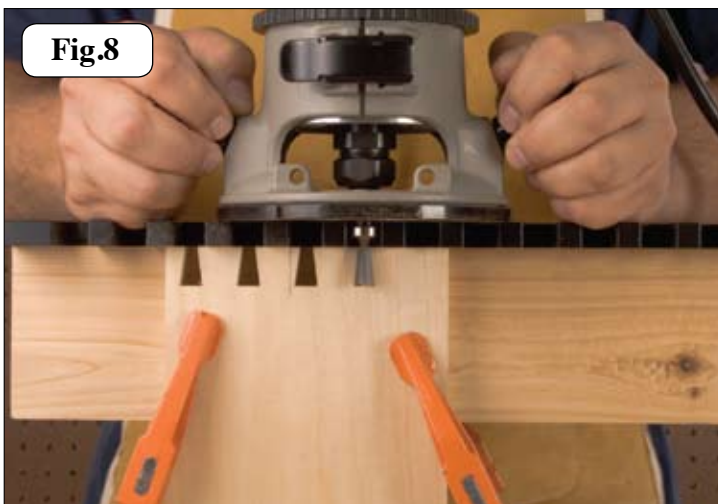

**Completed Tail Cut:**

Your completed tail cut stock should look like the photograph shown below in **Fig. 9**

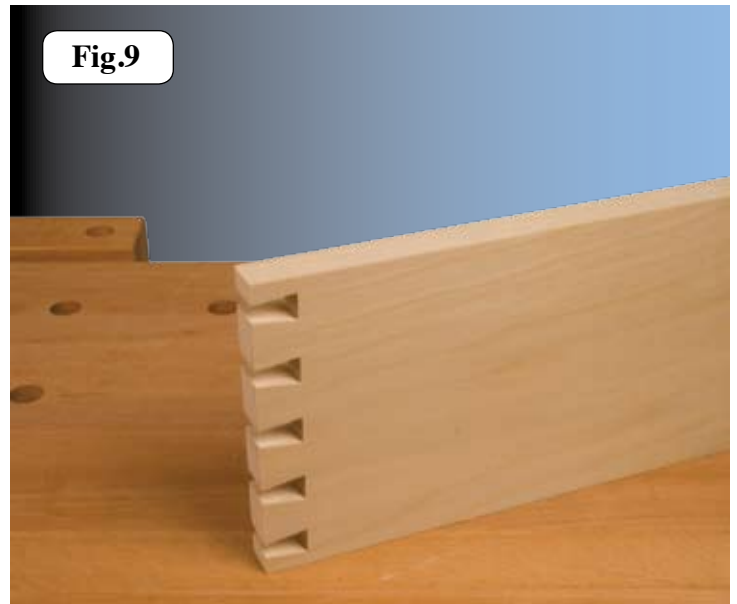

**When Stock is Wider Than Dovetail Jig:**

*When the stock is wider than the jig, cut all of your tails, then scribe the outline of the last tail opening on the right side of the jig before un-clamping. Once scribed, un-clamp jig, slide the jig to the right, aligning the last tail opening on the left side of the jig with the scribed lines. Repeat this process for the entire width of you stock.*

# Cutting The Pins

## Making the Pin Cut:

Pin cuts are always made after cutting the tails. The reason for this is, you will use the tail to cut to lay out the positioning of the pins of your joint.

### 1. Secure stock to Jig

A. Prepare the stock to be dovetailed by joining all four edges followed by cutting the ends square. With the Peachtree Dovetail Jig you can use one thickness stock for the pin cut and a different thickness stock for you tail cut.

B. Clamp your stock to be dovetailed vertically into you workbench vise. **Fig 10**



C. To mark the location of the pins you will use the tail stock piece you just cut as marking guide. Position the tail stock on top of the pin board in the correct right angle position See **Fig. 11** . Make sure all three edges line up flush with the pin board (piece to be cut). Using a utility knife, scribing knife or a fine tipped pencil mark the location of one dovetail opening on the end grain of the pin board.

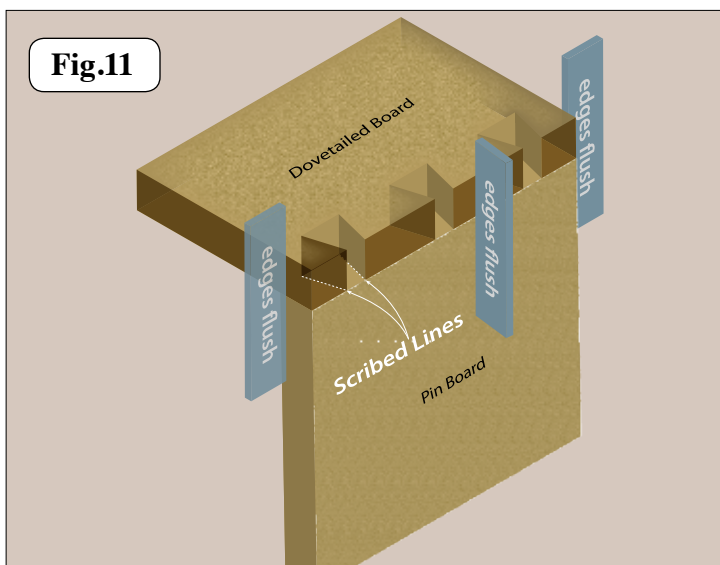

D. Place the mounted dovetail jig (pin side) on the end of stock. Position the jig, so that the two edges of one of the pins line up with the two scribed lines. Note: the angles that you marked with your scribing tool for your dovetail opening will match both side edges of one pin on your dovetail jig. See **Fig.12**. Make sure dovetail jig rest's flat on the pin stock and secure in place with F-clamps or C-clamps. You will be removing the stock that is exposed between the pin openings of the dovetail jig using the straight router bit.

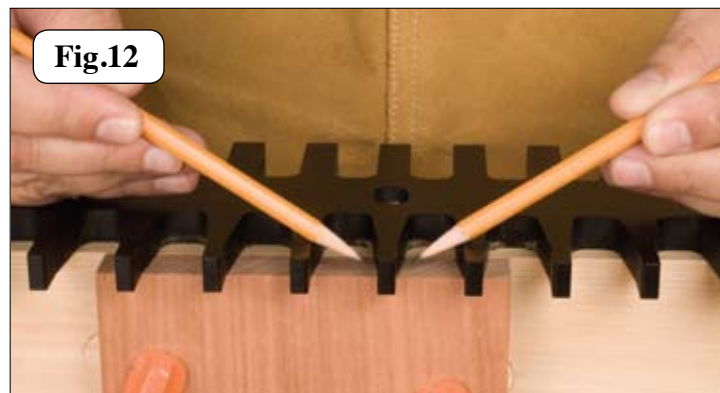

**Fig.12**

### Caution:

*Make sure when clamping your stock to the jig your clamp heads are not in the path of the router bit.*

See **Fig.13**



**Fig.13**

E. Place the straight router bit with bearing guide into your router and secure router bit collet tightly. Adjust the base of your router for depth of cut by adding the thickness of the tail stock piece plus 1/2" for the thickness of the dovetail jig. If desired, add an additional 1/32" or more for sanding the edge perfectly flush after assembly of joint. Another way of setting your bit height is to place your tail side stock on top of the jig. Place the router with bit on top of stock, with bit hanging over edge between the fingers of the jig. Now lower the router bit until it touches the top of the pin stock and then secure router bit in place. See **Fig. 14**

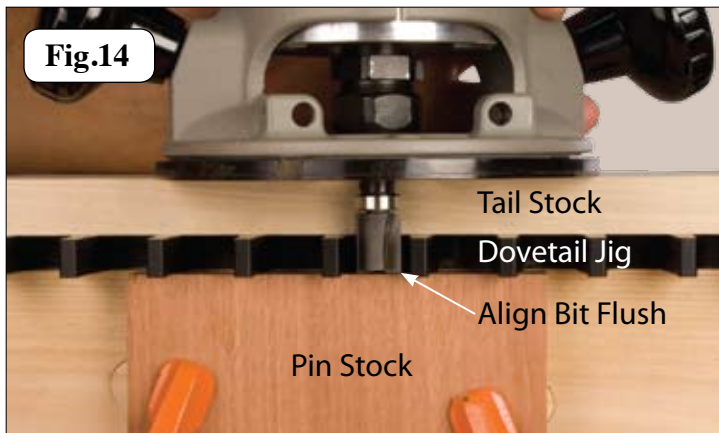

**Caution:**

Make sure bearing contacts dovetail jig by at least 1/8" or more before starting cut. If bearing does not contact jig properly it may result in injury or damaging the dovetail jig. See **Fig.15**. In order cut dovetails into thinner stock, you must use optional router bits which are sold separately.

**Caution:**

To prevent damaging your dovetail jig while router is turned on - Do not tip the router, always keep the router flat on jig. Do not lift the router up between the fingers while router is on. When routing of joint is complete, turn router off and wait for bit to come to a complete stop before removing router off of the dovetail jig. Do not force the router bit, or cut to fast, as this may result in tear-out, splintering of the stock or even loss of control. Moving the router to slow could result in burning of your stock. Feed the router bit into the stock smooth and controllable rate.



**Completed Pin Cut:**

Your completed pin cut stock should look like the photograph shown below in **Fig. 17**

F. (Always wear eye protection) Cut your stock standing behind mounting block. See **Fig. 16**. This will allow you to pull the router towards you while making the cut, giving you a smoother, more controllable cut. This also will keep the wood chips directed away from you. Place your router flat on top of the dovetail jig surface with the bit in between one of the openings. Be sure the cutter is not contacting the wood surface before turning your router on. Holding the router firmly, turn it on, start by taking very light pass across the face of your pin stock. This step prevents chipping or tear-out of the stock. Proceed to guide the bearing and router bit along the edge of each of the pin side openings of the dovetail jig. Pulling the router all the way back to each of the pin slots removing the stock down to the scribed lines, See **Fig.16** On wood that tends to easily chip, a thin light pass from the face of the stock to the back of the dovetail jig will help eliminate tear-out.



**When Stock is Wider Than Dovetail Jig:**

When the stock is wider than the jig, cut all of your pins, then scribe the outline of the last pin opening on the right side of the jig before un-clamping. Once scribed, un-clamp jig, slide the jig to the right, aligning the last pin opening on the left side of the jig with the scribed lines. Repeat this process for the entire width of you stock.

## Assemble the Dovetail Joints:

Assemble the pin-board and the tail-board. The Joint should have a snug - sliding fit as shown in **Fig. 18**. If you have to force the joint together with a mallet, it may result in splitting the dovetailed sockets, as well as forcing the glue out of the joint. To loose of a fit, may produce wobbling and a weak dovetail joint. If you have added the extra 1/32" or more to your joint, it can now be cleaned up by sanding the joint flush after gluing. If satisfied with the fit of your dovetail joint - glue, clamp and finish your project. If the dovetails are in need of adjustment, this is done on the pin side of the dovetail jig (follow steps below). The tail side or of the joint remains the same.



## If Joints Are To Loose:

You will need to make the joint tighter, by making the pins larger, lightly loosen the 4 screws that hold the dovetail jig to the mounting block, just enough to be able to tap the jig forward with a wooden mallet or scrap block of wood (do not use a metal hammer directly on jig as it may damage the dovetail jig). Tap the dovetail jig forward on the mounting block. The distance of this adjustment usually is made in .001" depending upon how loose the joint is. Start out by tapping the dovetail jig forward on the block .002" See **Fig. 19**. This means that each pin size is increased by .004" wider (.002" on each side of the pin = .004"). Make sure your adjustment remains parallel across the dovetail jig to the mounting block. Once adjusted, tighten the four screws - repeat cutting process with different piece of stock until you obtain the desired fit.

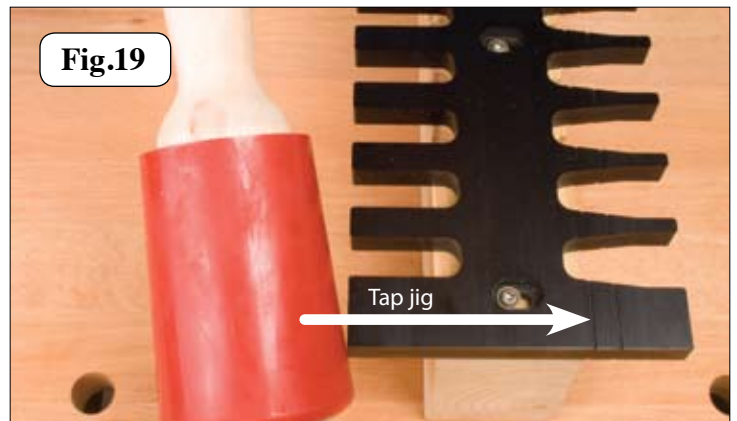

### **Please Note:**

*When making test cuts it is important that your test stock is exactly the same size thickness as your project stock. Each time you change the thickness of your stock, you must adjust the dovetail jig accordingly.*

## If joints are to tight:

You will need to make the joint looser by making the pins smaller, slightly loosen the 4 screws that hold the dovetail jig to the mounting block, just enough to be able to tap the jig backward with a wooden mallet or scrap block of wood (do not use a metal hammer directly on jig as it may damage the dovetail jig). Tap the dovetail jig backward on the mounting block. The distance of this adjustment usually is made in .001" depending upon how tight the joint is. Start out by tapping the dovetail jig backward on the block .002". See **Fig. 20**. This means that each pin size is decreased by .004" smaller (.002" on each side of the pin = .004"). Make sure your adjustment remains parallel across the dovetail jig to the mounting block. Once adjustment is made, tighten four screws and repeat cutting process with different piece of stock until you obtain desired fit.

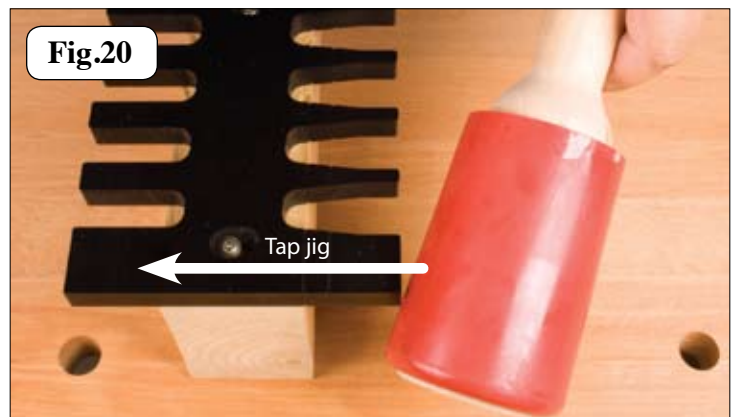

### **Please Note:**

*When making test cuts it is important that your test stock is exactly the same size thickness as your project stock. Each time you change the thickness of your stock, you must adjust the dovetail jig accordingly.*



# Various Dovetail Jig Uses

## Using your dovetail jig on a router table:

To use your Peachtree dovetail jig on a router table, you will follow the exact same directions as detailed in this instruction manual, with an exception. You do not clamp your stock into your work bench vise. Once the stock is clamped into your jig you will then flip the jig with stock up-side down to be run on your router table. (See Fig. 21)

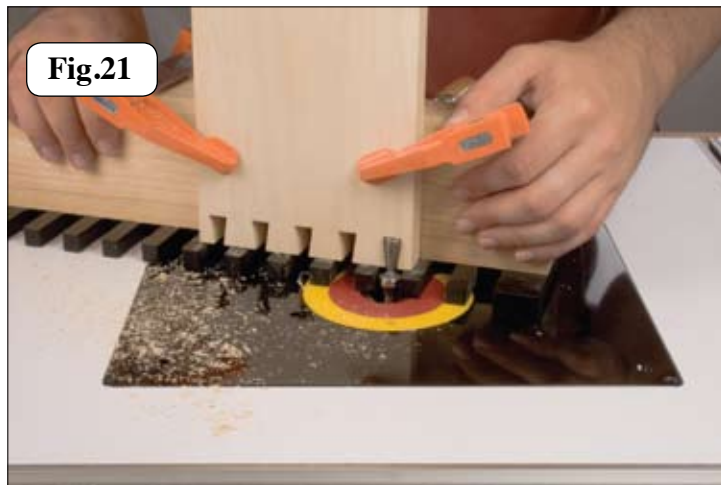

## Thinner stock using “standard” bits:

You are able to do thinner stock using the bits that came with your set, leaving a larger amount of cut-off waste. Since the bearing of the bit must ride in the template by 1/8” or more, the standard bits will leave larger waste to be removed once the joint is complete. See (Fig. 22)

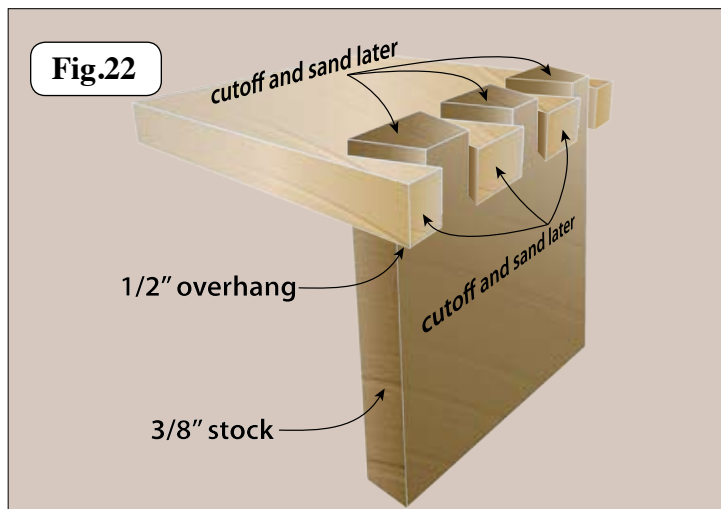

### Caution:

*Make sure bearing contacts dovetail jig by at least 1/8” or more before starting cut. If bearing does not contact jig properly it may result in injury or damaging the dovetail jig. See Fig.15. In order cut dovetails into thinner stock, you must use optional router bits which are sold separately.*

## Cutting stock thickness; 1/4” to 1/2”:

Optional router bits for cutting 1/4” to 1/2” stock. We have designed two shorter router bits that are the exact same finished profile as the standard bits that came with the dovetail jig.



When using these bits, you will not have make any adjustments to the jig. The only adjustment that is made is for the thickness stock we are cutting. Use the two bits together, or use one of these bits in conjunction with one of the standard bits when cutting two different thickness stocks as shown in example below (See Fig. 23). Keep in mind, when setting up for this type of cut, you would set the bit up for the opposing stock thickness. We used the standard dovetail bit that came with the dovetail jig to cut the tails and we used the straight bit from the 1/4” to 1/2” set to cut the shorter pins.

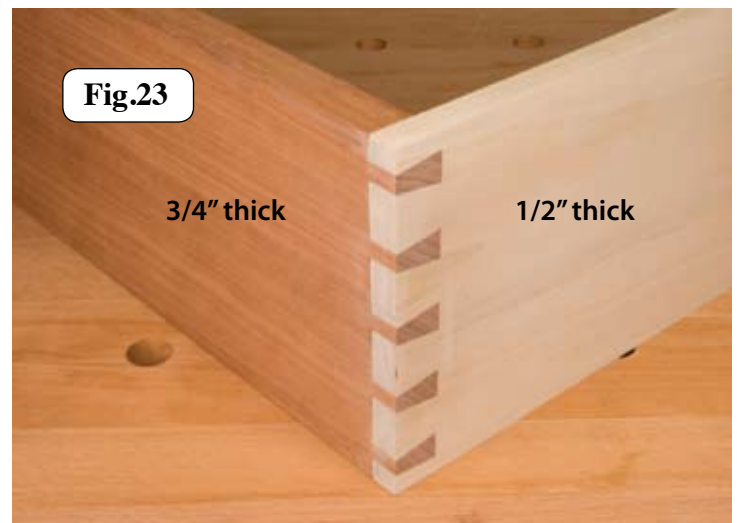

This joint shows 1/2” thick stock for the tails and 3/4” stock for the pins.

### Please Note:

*When cutting with the optional router bits, follow the all the instructions previously outlined in this manual. Make necessary adjustment for thinner stock pieces.*

## Cutting stock thickness; 1/8” to 3/8”:

Optional router bits for cutting 1/8” to 3/8” stock. We have designed two smaller router bits that work from the second scribe line on your dovetail jig. In order to use these bits, you must either attach a 3/8” spacer fence on you current mounting block or make a wider mounting block.



### Prepare The Mounting Block Thinner Stock:

In order to cut thinner stock, you must make the pins smaller. This is achieved by adding a 3/8" spacer (made out of MDF or solid wood) to the face of your mounting block (Fig. 24) not included. You can also achieve this by making a thicker mounting block - not included. It is essential that the mounting block is accurately machined so it is 90° to the dovetail jig. It can be made from a solid block or laminated. The block needs to be 2-5/8" thick x 3-1/2" high x 18" long. For different size dovetails we recommend you change your mounting block to provide solid, continuous support when your bit passes through the back of your stock.

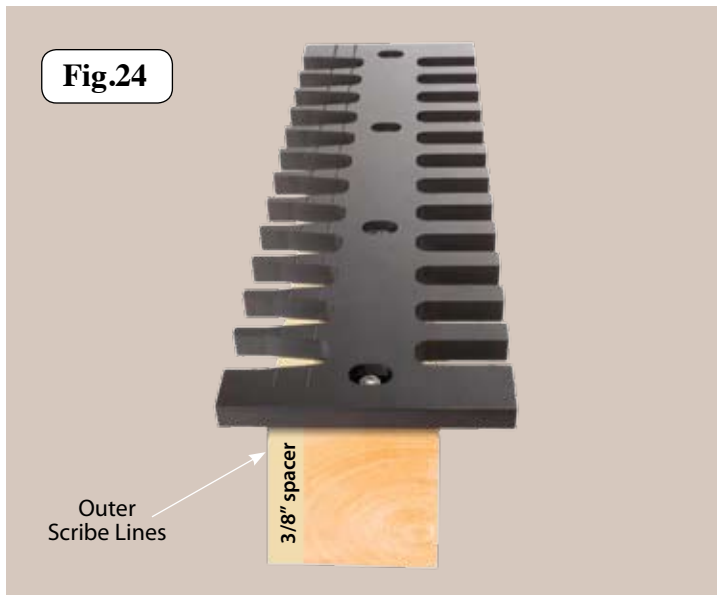

### Mount The Jig To A Thicker Mounting Block:

Mount the thicker block to the dovetail jig the exact same way that it was outlined in the beginning of the instruction manual. There are two scribed lines that run across the underside and the top side of the dovetail jig on the pin side of the jig itself (Fig. 25). The outside line is used to line up the mounting block or spacer block when using the smaller router bit set for cutting dovetails in 1/8" to 3/8" stock. Match this line to the top edge of the mounting block, it is important that the scribed line on the template jig and the stock are parallel. Drill through the four holes and insert the screws into the middle of the elongated holes. Tighten securely. The 15" Dovetail Jig can be used either in an upright position locked in a vise or inverted onto a router table when working with shorter stock.



Once you have mounted your dovetail jig to the wider block, you will be able to use the bit set that cuts from 1/8" to 3/8" stock. These router bits can only be used in conjunction with each other since they work off of a smaller section of the dovetail jig.

#### **Please Note:**

*When cutting with the optional router bits, follow the all the instructions previously outlined in this manual. Make necessary adjustment for thinner stock pieces.*

## Creating Angled Dovetails

### Angled Dovetails:

Cutting angled dovetails is done the same way you would do 90° dovetails. In this example we have a cut 22½° angle on our tail cut. Follow the instructions previously outlined in this manual to center the stock, then clamp your jig to the stock and make the cut. Make sure you position the jig to have at least 1/4" of stock on the outer tail. See (Fig. 26)

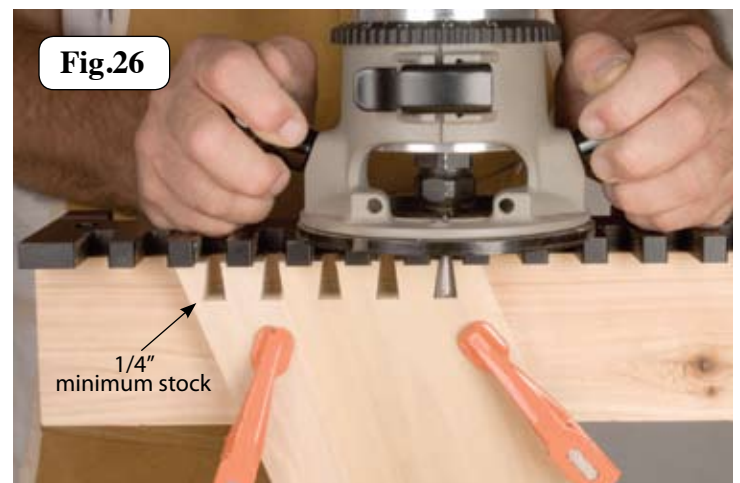

### Completed Angled Tail Cut:

Your completed tail cut stock should look like the one shown below. See (Fig. 27)



### Making the Pin Cut:

Follow the instructions previously outlined in this manual to align the stock to the jig, then clamp your jig to the stock and make the cut. See (Fig. 28)



### Completed Angled Pin Cut:

Your completed tail cut stock should look like the one shown below. See (Fig. 29)

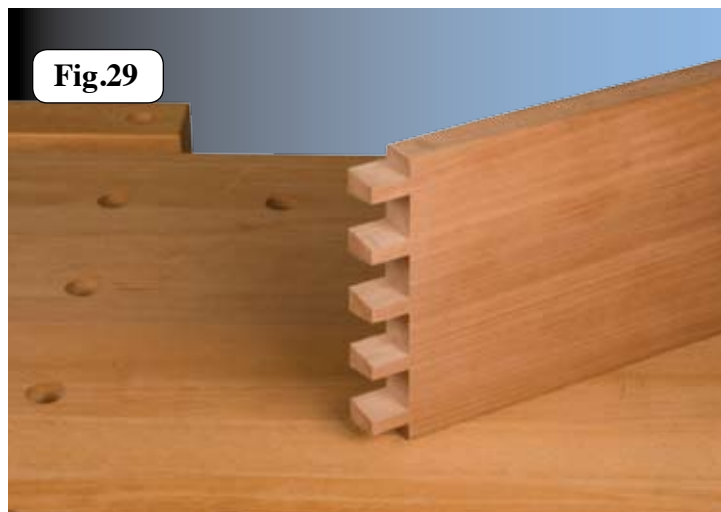

### Assemble the Angled Dovetail Joints:

Assemble the pin-board and the tail-board. The Joint should have a snug - sliding fit as shown in Fig. 30. If you have to force the joint together with a mallet, it may result in splitting the dovetailed sockets, as well as forcing the glue out of the joint. To loose of a fit, may produce wobbling and a weak dovetail joint. If you have added the extra 1/32" or more to your joint, it can now be cleaned up by sanding the joint flush after gluing. If satisfied with the fit of your dovetail joint - glue, clamp and finish your project. If the dovetails are in need of adjustment, this is done on the pin side of the dovetail jig (refer previous instruction for joint adjustment).



#### *Please Note:*

*You can use angled spacing blocks between your stock and the jig to cut virtually any type of angle from acute to obtuse. If you can clamp it to the jig you can dovetail it.*

## Creating Skip Spacing Joints

### Skip Spacing Dovetail Joints:

One of the unique features of this system is, you can skip spaces between the tail cut and pin cut to vary the size of the joint. You can also make an endless amount of different widths by making one, cut an then sliding the jig to one side and make a second cut to vary the width of the joints. This following example will show you the skip spacing method.

#### *Please Note:*

*When using this method you will mark the location of all the pins on the opposing stock.*

### Cutting The Tail:

We will be cutting every other tail cut on the jig. Follow the instructions previously outlined in this manual to center the stock, then clamp your jig to the stock and make every other tail cut. See (Fig. 31)



### Completed Skip Spacing Of Tail Cut:

Your completed tail cut stock should look like the one shown below. See (Fig. 32)



### Making The Pin Cut:

Pin cuts are always made after cutting the tails. The reason for this is, you will use the tail cuts to layout the positioning of the pins of your joint. You will follow the instructions previously outlined in this manual to align the stock to the jig with one exception; you must mark all of the pin locations on the stock to be cut.

### Making Pin Cut Locations:

To mark the location of the pins you will use the tail stock piece you just cut as marking guide. Position the tail stock on top of the pin board in the correct right angle position See Fig. 33 . Make sure all three edges line up flush with the pin board (piece to be cut). Using a utility knife, scribing knife or a fine tipped pencil mark the location of ALL dovetail openings on the end grain of the pin board.

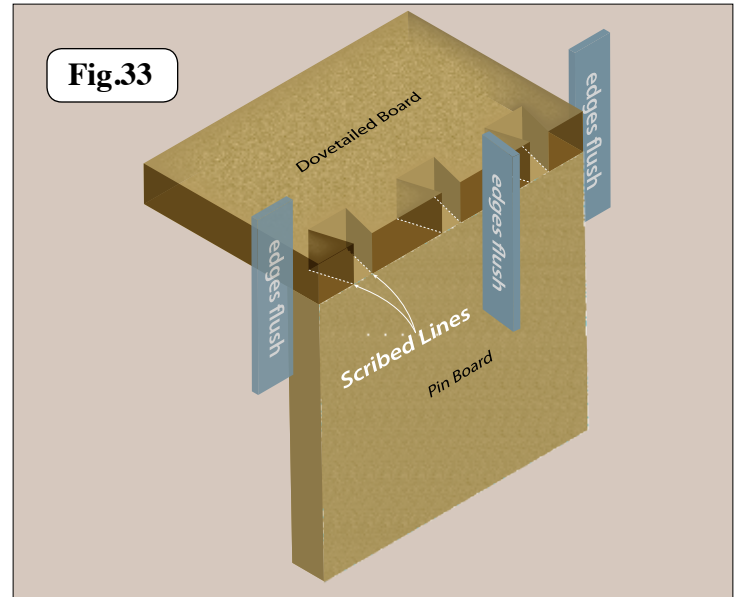

### Marking Stock to be Removed:

Once you have marked the locations of your pins, use a magic marker or pencil to mark the stock to be removed between the pins. See (Fig. 34)



### Stock removal of pin cuts:

Follow the instructions previously outlined in this manual to align the stock to the jig for the pin cut, then clamp your jig to the stock, set your bit height and make the cut. The first pass you will remove the stock in every pin cut opening. Your completed pin cut should look like **Fig. 35**. Take note, the pins that still have the magic marker on them need to be removed. You can use your band saw or a hand saw to remove them, or follow instructions below on how to use your dovetail jig to remove the excess pin material.



### Make The Cut:

When making the cut, be sure to only remove the stock that has been marked. See (**Fig. 37**)

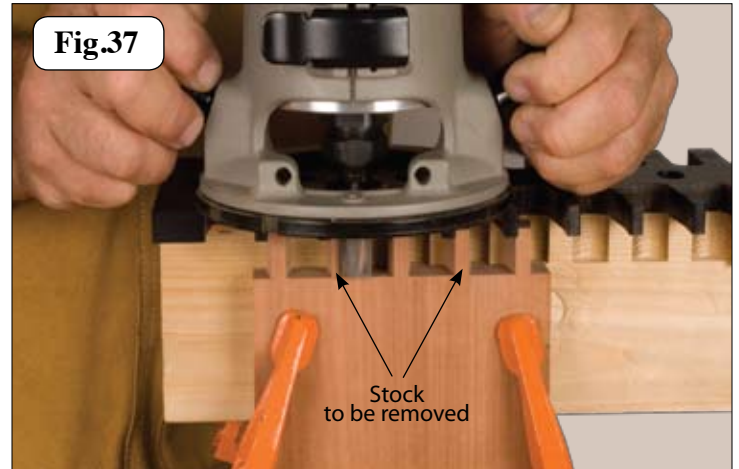

After making the cut, remove the jig - and your stock should look like this, See (**Fig. 38**). Note, there will be a small piece of the pin left that needs to be removed.

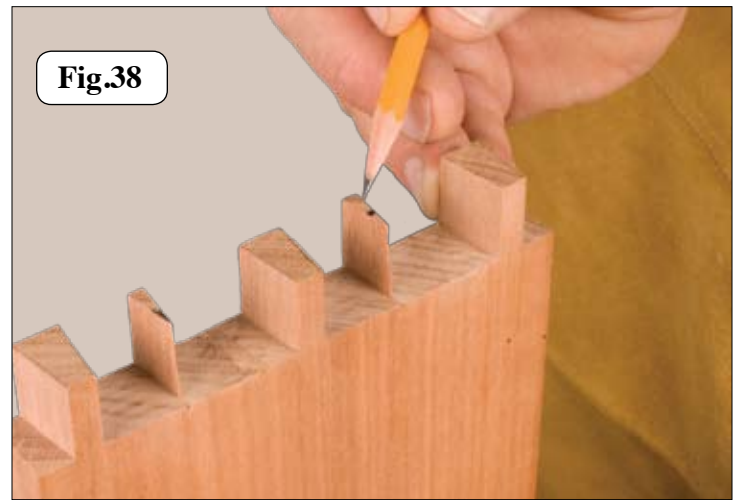

### Removing Excess Pins:

Slide the jig to the Left and align the jig so that the back edge of the fingers rest on part of the pins See (**Fig. 36**), then clamp your jig to the stock. Note that we will be removing the stock that still has the markings on it.

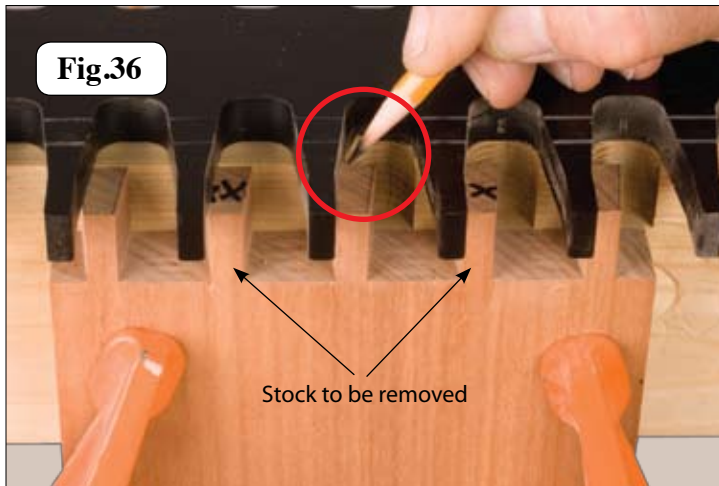

### Removing Excess Pins:

Slide the jig to the Right and align the jig so the back edge of the fingers rest on part of the pins See (**Fig. 39**), then clamp your jig to the stock. Note that we will be removing the stock that still has the markings on it.

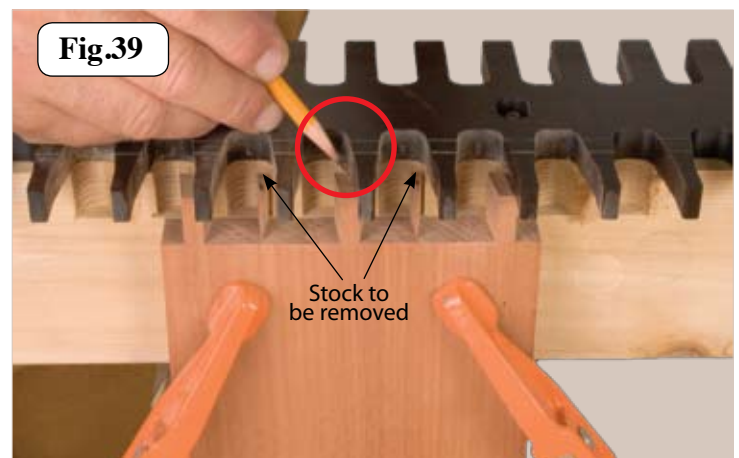

### *Please Note:*

*The Dovetail jig must rest flat on part of the pins to maintain the correct depth of cut, which will provide a stable work surface.*

### Make The Cut:

When making the cut, be sure to only remove the stock that has been marked. See (Fig. 40)

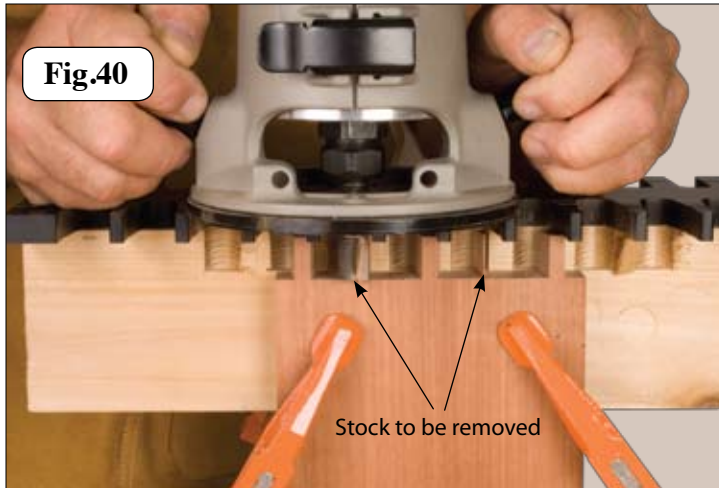

#### ***Please Note:***

*The Dovetail jig must rest flat on part of the pins to maintain the correct depth of cut, which will provide a stable work surface.*

### Completed Skip Spacing of Pin Cut:

Your completed tail cut stock should look like the one shown below. See (Fig. 41)

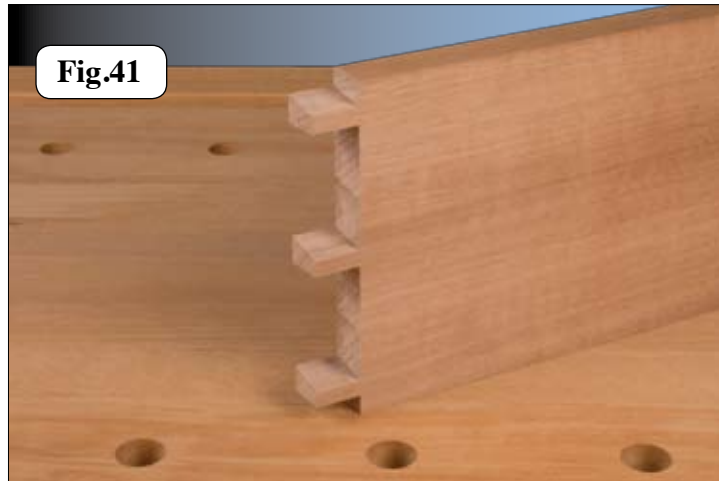

### Assemble the Skip Spacing Joint:

Assemble the pin-board and the tail-board. The Joint should have a snug - sliding fit as shown in Fig. 42. If you have to force the joint together with a mallet, it may result in splitting the dovetailed sockets, as well as forcing the glue out of the joint. To loose of a fit, may produce wobbling and a weak dovetail joint. If you have added the extra 1/32" or more to your joint, it can now be cleaned up by sanding the joint flush after gluing. If satisfied with the fit of your dovetail joint - glue, clamp and finish your project. If the dovetails are in need of adjustment, this is done on the pin side of the dovetail jig (refer previous instruction for joint adjustment).



This method of skip spacing has an endless amount of possibilities when making your projects. It is up to you as to which socket to skip. You can cut one, skip one, cut one, skip one, or cut two, skip one, cut two - simply mix it up. You will also use this same basic principal to slide the jig one side to make wider pins and tails.

#### ***Please Note:***

*When using either method of skip spacing or slide spacing, the jig must rest flat on part of the pins to maintain the correct depth, which will provide a stable work surface.*

# Create Box or Hinge Joints

## Box Joints / Hinge Joint:

Your Dovetail Jig is capable of doing box joints in stock from 1/2" to 3/4" thick, using the tail side of the jig only with an optional box-joint router bit and bearing. The fingers will be spaced 9/16" on center.



## Cutting the joint:

Install your box joint bit into your router and secure in place. To line up your dovetail jig for making the cut, first mark the center of your stock to be cut. Measure and mark on each side of the center mark at 5/16". Next, align two inside edges of one of the tail side openings of the jig to those marks (See **Fig.1** for tail side). Clamp your jig in place, adjust the height of the bit for the stock thickness (previously outlined in this instruction manual), then make the cut. See (**Fig. 43**)

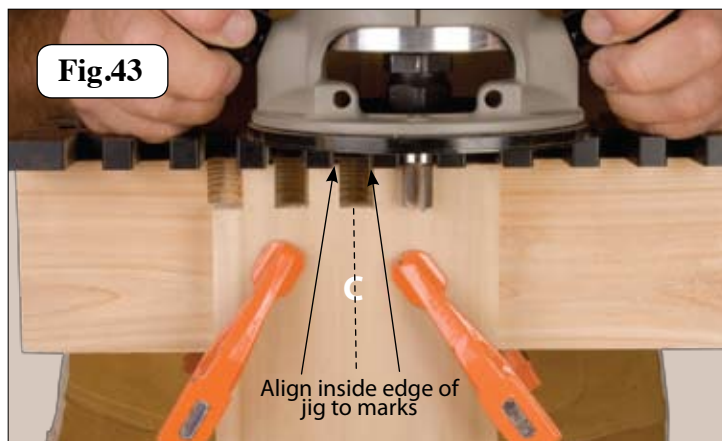

## Opposing Joint Cut:

To line up your dovetail jig for making the opposing cut, mark the center of your stock to be cut. Measure and mark on each side of the center mark at 1/4". Next, align two outside edges of one of the tail side fingers of the jig to those marks. Clamp your jig in place, then make the cut. See (**Fig. 44**)

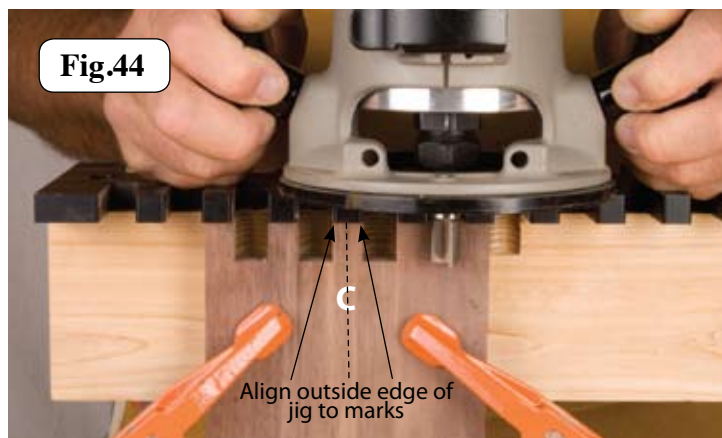

## Assemble the Box Joint

The Joint should have a snug - sliding fit. If you have to force the joint together with a mallet, it may result in splitting the stock, as well as forcing the glue out of the joint. If you have added the extra 1/16" or more to your joint, it can now be cleaned up by sanding the joint flush after gluing. If satisfied with the fit of your box joint - glue, clamp and finish your project. We have decided to make our version into a moveable hinge joint. To do this we have rounded over both sides of the stock with a 3/8" roundover router bit prior to cutting the stock. Once the joint was complete, we drilled a 3/8" hole down the length of the joint and inserted a dowel rod (See **Fig 45**).

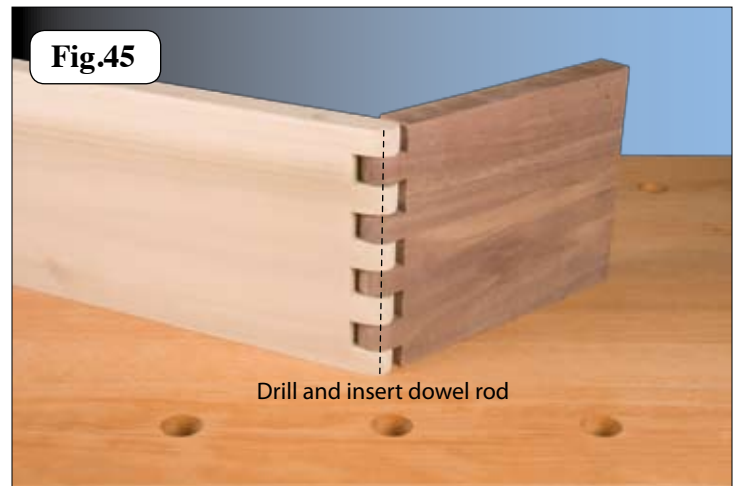

## The Peachtree Dovetail Jig

The Peachtree Dovetail Jig is one of the most versatile jigs available. In this manual we have outlined several different types of joints as well as thickness stock that can be made. The possibilities that can be applied are virtually endless. Thank you for your purchase and we hope you enjoy your brand new Peachtree Dovetail Jig!

For accessory router bits, visit us online at [www.ptreeusa.com](http://www.ptreeusa.com) or call us toll free at: 1-888-512-9069